

DMT242 Dewpoint Transmitter for OEM Applications



Due to its wide measurement range and high long-term stability, the DMT242 is an ideal choice for low dew point industrial applications such as compressed air dryers, plastic dryers and other OEM applications.

Vaisala DRYCAP®

The Vaisala DRYCAP® Dewpoint Transmitter DMT242 provides reliable and stable measurements for industrial dryer applications. It is designed for extreme conditions.

DMT242 incorporates the Vaisala DRYCAP® thin film polymer sensor and auto-calibration software. The standard sensor choice for dry gases and desiccant dryers is DRYCAP® 180M and for more humid applications such as refrigeration dryers, a DRYCAP® 180S sensor.

Both the sensors are immune to particulate contamination, water condensation, oil vapor and most chemicals. Because the sensor withstands condensation, its performance is unmatched for low dew point applications that experience process water spikes, such as pipeline condensation during a system failure or start-up.

上海博众测量技术有限公司

Bodhi (Shanghai) measurement technology Co.,Ltd.
NO.32,ShuPing Road, JiadingDistrict, ZIP201808,
Shanghai R.P.China

TEL: 0086 21 6630 8161/62/63
FAX: 0086 21 6630 8167

The auto-calibration software works on-line while the process is running. If the measurement accuracy is not confirmed, corrections are made automatically. The DMT242 adjusts the measurement, corrects dry-end drifts and continues to function. Calibration occurs quickly, and with corrections so minor, it will go unnoticed.

Compact, Rugged and Intelligent

Due to its compact size, DMT242 is quickly and easily installed in tight spaces.

Users can perform a field-check by using the Vaisala DRYCAP® Hand-Held Dewpoint Meter DM70. The transmitter can be sent to Vaisala Service for NIST traceable calibration. The recommended calibration interval is every two years.

Features/Benefits

- Ideal choice for industrial dryer applications
- Incorporates advanced Vaisala DRYCAP® Sensor and enhanced auto-calibration software
- Long-term stability in low dew points
- Fast response time
- Two sensor options cover dew point measurement range from -60 ... +60 °C (-76 ... +140 °F) with an accuracy of ±2 °C (±3.6 °F)
- Withstands condensation
- NIST traceable (certificate included)
- Compatible with Vaisala DRYCAP® Hand-Held Dewpoint Meter DM70

Dimensions

Dimensions in mm (inches)

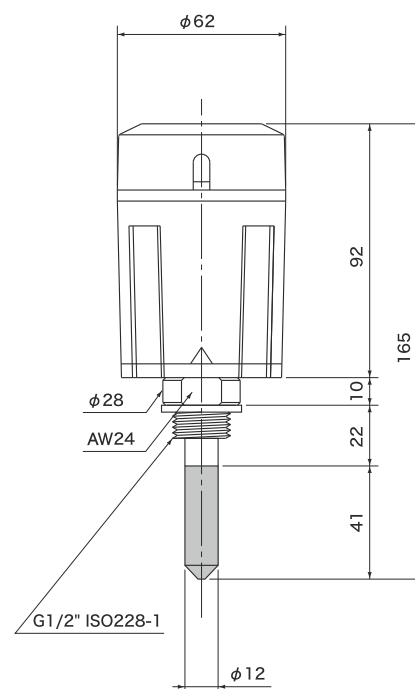

Technical Data

Dew Point Temperature

Measurement range (typical)	-60 ... +60 °C (-76 ... +140 °F)
Analog output scalings	
Option A	-80 ... +20 °C (-112 ... +68 °F) T_d
Option B	-60 ... +60 °C (-76 ... +140 °F) T_d
Option X	free scaling

(when the dew point is below 0 °C (32 °F), the transmitter outputs frost point)

Accuracy with DRYCAP® 180M ± 2 °C (± 3.6 °F)
(see graph below)

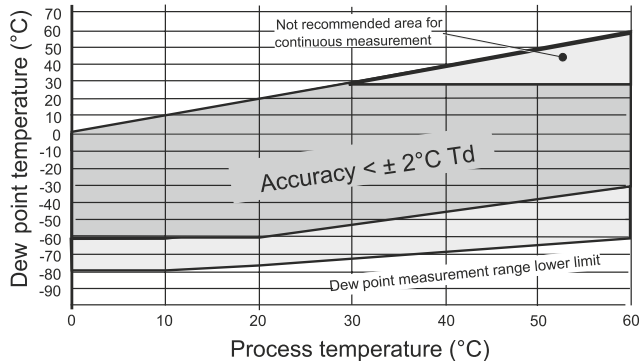

DEW POINT ACCURACY VS. MEASUREMENT CONDITIONS

Response time 63 % [90 %] at +20 °C gas temperature
Flow rate >1 l/min and 1 bar pressure

-60 → -20 °C Td (-76 → -4 °F Td)	5 s [10 s]
-20 → -60 °C Td (-4 → -76 °F Td)	45 s [10 min]

Accuracy with DRYCAP® 180S ± 2 °C (± 3.6 °F)
(see graph below)

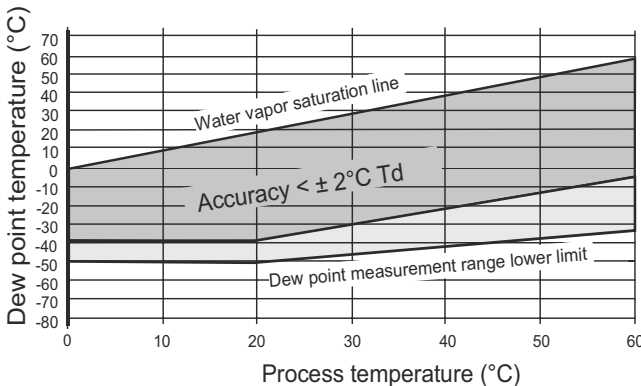

Operating Environment

Temperature	0 ... +60 °C (32 ... +140 °F)
higher temperature peaks	Short-term OK
Relative humidity	0 ... 100 %RH
Pressure	0 ... 20 bara (0 ... 290 psia)
Sample flow rate	no effect

Output

Analog output	4 ... 20 mA
Resolution for analog output	± 0.002 mA
Typical temperature dependence	0.0008 mA/ °C
Serial line for service use	RS232

General

Sensor	DRYCAP® 180M
Optimal sensor for refrigeration dryers	DRYCAP® 180S
Operating voltage	18 - 35 VDC, 20 - 28 VAC
Power consumption at 24 VDC	max. 220 mA
External load for analog output	max. 500 Ω
Optional connection cable with DMT242 connector	2 m or 10 m
Connector for supply voltage and signal output	
max. wire size	0.75 mm ²
max. cable diameter	6.5 mm /PG7
Service cable for serial interface RS232	product code DMT242RS
Probe material (wetted parts)	stainless steel (AISI 316L)
Sensor protection	stainless steel sintered filter (HM47280)
Mechanical connection	G $\frac{1}{2}$ " ISO228-1 thread with bonded seal ring (U-seal)
Electronics housing material	plastic (ABS/PC)
Housing classification	IP65 (NEMA4)
Weight	225 g
Storage temperature range	-40 ... +70 °C, (-40 ... +158 °F)
Complies with the EMC standard EN61326-1, Electrical equipment for measurement, control and laboratory use - EMC requirements; Industrial environment.	



上海博众测量技术有限公司

Bodhi (Shanghai) measurement technology Co.,Ltd.
NO.32, ShuPing Road, Jiading District, ZIP201808,
Shanghai R.P.China
TEL: 0086 21 6630 8161/62/63
FAX: 0086 21 6630 8167

